

Energy Recovery Control Strategy of Motor with Supercapacitor

Biao Cao

School of Mechanical Engineering
University of Shanghai for Science and
Technology
Shanghai, China
840517959@qq.com

Chao Bi

School of Mechanical Engineering
University of Shanghai for Science and
Technology
Shanghai, China
bichao@usst.edu.cn

Zhen Peng

School of Mechanical Engineering
University of Shanghai for Science and
Technology
Shanghai, China
2835544650@qq.com

Abstract—This paper introduces a system for electric braking energy recovery of the rotational system with brushless DC motor. The energy storage unit is composed of supercapacitor (SC) bank. The power module combines the bidirectional DC/DC converter with buck and boost circuits. The SC bank can provide electric energy for starting, and the energy can be recovered quickly into the SC bank in the electric braking state. The experimental results verify the effectiveness of this control strategy, and the efficiency improvement in the energy utilization is introduced.

Keywords—supercapacitor, BLDC motor, bidirectional DC/DC converter, energy recovery, control strategy

I. INTRODUCTION

Supercapacitors, also known as electric double layer capacitors, are a new type of energy storage component developed in the 1960s. Different from conventional capacitors, its capacity can reach the Farad level or even thousands of Farads. It possesses the characteristics of high power density, fast charge and discharge speed, long cycle life, wide operating temperature range, high reliability and no pollution [1-3]. The emergence of SC fills the gap between traditional electrostatic capacitors and chemical power sources, and has been valued by many countries for its superior performance and potential application prospects. At present, the application of SC energy storage technology has received extensive attention in many fields [4-6].

The energy recovery has been concerned in modern electrical vehicle (EV) system. In the electric braking energy recovery system of EV, it is expected that the energy storage device can provide high power when the vehicle starts or climbs, which helps reduce the high energy demand from the main power source. When the vehicle stops or goes downhill, the energy storage device acts as a recycling device to store the kinetic energy of the vehicle, and this energy was wasted in the form of heat in the normal vehicles [7-8]. By recycling this part of the electric energy, the significant benefits of energy saving and consumption reduction can be achieved. Among the many energy storage devices, supercapacitors with unique performance are very attractive.

As a new type of energy storage element, the SC charge and discharge curves are closer to the capacitor than the battery, so it is more suitable for some instantaneous peak current applications to make up for the shortage of traditional batteries. The following issues must be noted in the use of supercapacitors:

1) SC are usually used in series or parallel to form a capacitor bank to match a higher load.

2) The charging target voltage of SC bank should be lower than its maximum rated voltage to extend its working life.

3) SC generally adopts the charging method of constant current first and then constant voltage. The constant current charging mode can make its voltage increase linearly, and quickly turn on the constant voltage charging mode after reaching the target voltage to avoid overcharging.

4) Due to the dispersion of characteristic parameters between each capacitor, voltage balance processing should be carried out during its use to prevent the unbalance phenomenon of single voltage in the process of charging and discharging, thus causing the failure of the whole energy storage system.

II. CONSIDERATIONS OF ENERGY RECOVERY SYSTEM

The electric braking energy recovery system based on SC should include three parts: main circuit system, bidirectional DC/DC control system and motor drive system. The main circuit can realize the bidirectional transmission of energy between the motor and the SC bank. The control loop completes the constant voltage and constant current output of the bidirectional DC/DC converter by collecting relevant data, and the motor drive circuit controls the start and stop states of the motor.

There are many circuit topologies that can implement the energy bidirectional flow function. The synchronous Buck circuit can be a bidirectional DC/DC converter that realizes forward buck and reverse boost functions, as in the synchronous Boost circuit. In a bidirectional DC/DC converter, a new topology can be obtained by replacing a rectifier diode in a classical topology circuit with a MOS transistor, such as a bidirectional Cuk circuit, Sepic circuit, and Zeta circuit. In the system developed by the authors, the synchronous rectification Buck-Boost circuit topology is realized by cascading synchronous Buck circuit and Boost circuit. The topology is simple and easy to control. The circuit can well meet the requirements of power conversion. Compared with a simple Buck or Boost circuit, not only realizing the bidirectional flow of energy, but it can also realize the functions of raising and lowering voltage in the same direction.

A. System Structure of the Experimental Platform

The block diagram of the motor electric braking energy recovery system based on SC is shown in Fig. 1. The SC bank and motor can transmit energy in both directions through a bidirectional DC/DC converter. The control unit based on STM32F334 can implement output that satisfies the system control strategy by collecting the voltage and

current parameters of SC bank and bidirectional DC/DC converter through internal arithmetic processing.

In the end, the following two processes can be realized. When the motor starts, the SC bank provides energy for it. When the motor is in the electric braking state, the electric braking energy is quickly recovered into the SC bank.

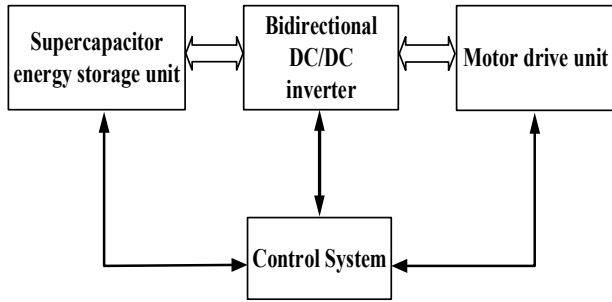

Fig. 1. Block diagram of the motor electric braking energy recovery system

B. Topology Configuration

In motor electric braking energy recovery system, it is important to choose an appropriate energy converter. The bidirectional synchronous rectification Buck-Boost converter can meet the requirements very well [9]. The circuit topology is shown in Fig. 2.

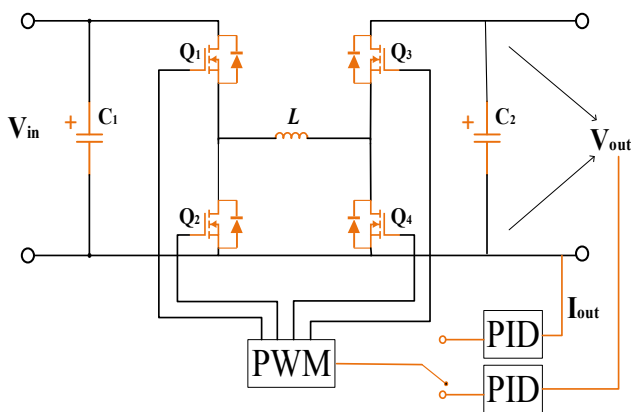

Fig. 2. Topology of bidirectional synchronous rectification Buck-Boost circuit

The circuit structure mainly includes four fully-controlled MOSFETs Q_1 , Q_2 , Q_3 , Q_4 and their parallel diodes, energy storage inductor L , input and output filter capacitors C_1 , C_2 . Where Q_1 and Q_2 are a pair of complementary conducting MOSFETs, and Q_3 and Q_4 are a pair of complementary conducting MOSFETs.

Since the bidirectional synchronous rectification Buck-Boost circuit is cascaded by synchronous Buck circuit and Boost circuit, the Buck circuit voltage gain formula is:

$$U_o/U_i = D_{bu} \quad (1)$$

The Boost circuit voltage gain formula is:

$$U_o/U_i = 1/(1-D_{bo}) \quad (2)$$

The formula for the Buck-Boost circuit voltage gain can be derived from (1) and (2) as:

$$U_o/U_i = D_{bu}/(1-D_{bo}) \quad (3)$$

where, D_{bu} is defined as the duty cycle of the Buck circuit, corresponding to the duty cycle of Q_1 in this circuit, and D_{bo} is defined as the duty ratio of the Boost circuit, corresponding to the duty cycle of the Q_4 . It can be seen from (3), whether the circuit operates in buck mode, boost mode or buck-boost mode, it essentially controls the buck duty cycle D_{bu} and the boost duty cycle D_{bo} .

C. Circuit System Design

Fig. 3 shows the main circuit topology of the motor energy recovery system. One side of the bidirectional DC/DC converter is connected to the three-phase winding of the motor, and the other side is connected to the SC bank.

The motor drive module is composed of 6 MOSFETs to control the start and stop states of the motor. Since there are parallel freewheel diodes inside the MOSFETs, when the motor is in the electric braking state, the power module is equivalent to the rectifier circuit. The alternating current generated by the motor is rectified into direct current, and is recovered into the SC bank through the bidirectional DC/DC converter.

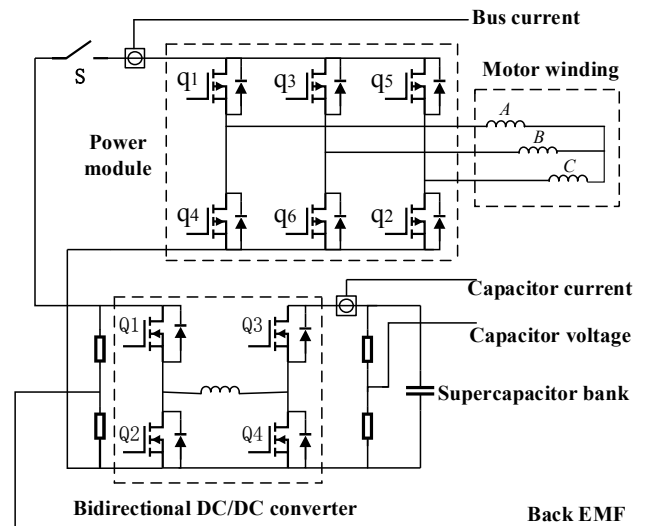

Fig. 3. Main circuit topology of the energy recovery system

To speed up the recovery of the motor electric braking energy into the SC bank with high efficiency, appropriate control strategies must be adopted, the operation of the system is as the following:

1) The power of the motor is supplied by the SC bank in motor starting or accelerating. If the voltage on the capacitor side is lower than the bus voltage, the bidirectional DC/DC converter operates in the boost mode. At this time, Q_3 is fully turned on, Q_4 is fully turned off, Q_1 and Q_2 are complementarily turned on. At this stage, the voltage of the SC bank is continuously reduced, and the control circuit will ensure that the bus voltage is maintained at a certain value no matter what the voltage of the SC bank is within a certain range. In the actual application field of EV, SC bank first

provides energy during the climbing or accelerating process, which can effectively alleviate the damage caused by the main power high-power discharge and effectively extend the life of endurance.

2) When the motor electric brakes, the SC bank is in the charging mode. In the early stage of electric braking, due to the higher motor speed, the back-emf generated is higher, and bidirectional DC/DC works in the buck mode to charge the SC bank; as the motor speed decreases, the back-emf generated gradually decreases, while the voltage of the SC bank rises, even higher than the back-emf of the motor. At this time, transistor Q_1 is fully turned on, Q_2 is fully turned off, and SC bank is continuously charged by controlling the turn on and turn off of Q_4 . That is, the voltage across the bidirectional DC/DC converter is constantly changing throughout the electric braking process. In order to maximize the recovery of the electric braking energy of the motor, the control circuit is required to automatically determine whether the bidirectional DC/DC operates in the boost or buck mode. Considering the charging characteristics of the SC and the safe working current of the MOSFETs, the system uses a constant current of 2A to charge the SC bank, so that the electric braking energy is transferred as much as possible and safely to the SC bank.

III. EXPERIMENTAL PLATFORM DESIGN

According to the working mechanism of motor starting and electric braking, the authors built a kinetic energy recovery experimental platform for brushless DC motor based on SC and bidirectional DC/DC converter. The experimental process mainly includes the start-up and the kinetic energy recovery experiment of the motor, respectively simulating the starting / (accelerating) and stopping / (decelerating) states of the EV during operation. In addition, in order to compare the effects of different motors on braking energy recovery, two sets of braking energy recovery tests were performed for different specifications of motors.

A. Design of Energy Storage Unit

Commercial supercapacitor typically has a cell voltage between 2.7 and 3V, and its single capacitance can up to several hundred to thousand Farads. Therefore, the use of SC is generally composed of multiple single capacitors in series or parallel to form SC bank. The number of SC bank in different applications is also very different, usually affected by several important factors: the amount of stored energy, the level of output voltage, and the ratio of energy release. The energy stored by the SC is typically 67% of the rated capacity, and the energy absorbed or released is about 33% of the stored energy. Based on these characteristics, the capacity and quantity of the SC required for the experiment can be derived.

The test system selects the BCAP0350 supercapacitor produced by Maxwell. The voltage of this capacitor is 2.7v and capacitance is 350F. The SC bank used in the system consists of 12 capacitors connected in series. The specific parameters of the SC bank are shown in Table I.

TABLE I. PARAMETERS OF THE SC BANK

Rated voltage	32.4V
Rated capacitance	29F
Internal resistance	38.4m Ω
Stored energy	4.2Wh

B. The Design of Experiment

Since the system mainly focuses on the realization process of the control strategy, the brushless DC motor commonly used in EV is selected in the experiment. Because the moment of inertia of the motor is too small, in order to better simulate the recovery of the motor electric braking energy, a flywheel is used in the experiment, and the flywheel is installed on the motor shaft to increase the moment of inertia of the rotating system. The specific performance parameters of motor-1 and motor-2 are shown in Table II.

TABLE II. PARAMETERS OF MOTOR-1 AND MOTOR-2

Parameters\Motors	Motor-1	Motor-2
Rated voltage	24V	24V
Pole pairs	4	2
Phase resistance	1.3 Ω	0.4 Ω
Motor constant	2 Nm / \sqrt{w}	9.8 Nm / \sqrt{w}

Among them, the motor-1 adopts BLDC motor used in ordinary electric appliances, whose magnet steel is a plastic magnet, and its motor-constant is low. The volume of motor-2 is substantially the same as the motor-1, but the rotor magnet is made of sintered Nd-Fe-B, and its magnetic energy is much higher than that of the plastic magnet.

TABLE III. PARAMETERS OF FLYWHEEL

Diameter	0.12m
Thickness	0.02m
Quality	1.75kg

The flywheel parameters are shown in Table III. The formula of the moment of inertia is:

$$J = mR^2/2 \quad (4)$$

Where, m is the quality of the flywheel and R is the radius of the flywheel. The moment of inertia of the flywheel can thus be calculated from (4), and it is 0.00315 kg \cdot m².

C. Experimental Operation and Analysis of Results

The test process is divided into three parts: motor electric braking voltage waveform acquisition test, the motor starting test and electric braking energy recovery test. In addition, the motor electric braking energy recovery experiments were compared with the above two motors.

Firstly, the motor is regulated to 3200 rpm by the motor driver, and make motor drives flywheel to rotate smoothly.

After the power is turned off, the motor is in the electric braking process and the electric braking voltage waveform is acquired. The DC voltage waveform obtained by rectifying the back electromotive force of the motor-1 is shown in Fig. 4. As the motor speed decreases, the electric brake voltage waveform shows a downward trend, and the whole voltage trend is roughly reduced from 30V to 0V.

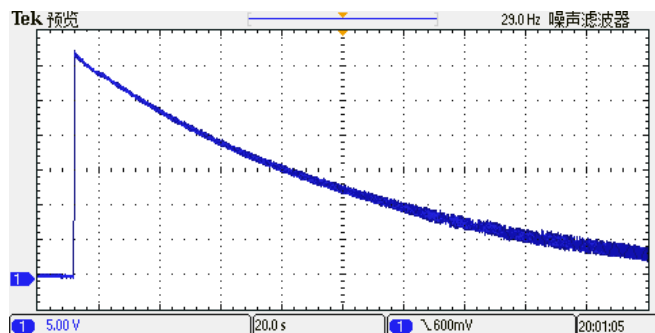

Fig. 4. Electric brake voltage waveform of motor-1

In the motor starting test, the input side of the bidirectional DC/DC converter is connected to the SC bank, and the output side is connected to the motor drive module. This stage is powered by the SC bank and stabilizes the output voltage at 24V through a bidirectional DC/DC converter. The test process mainly simulates the start or uphill state of the EV. The SC bank can provide a large output power and reduce the high power demand for the main power supply. Many EVs are powered by lithium batteries, which are sensitive to output power. The starting process requires a large power supply, so it is very meaningful to provide the motor starting power from the SC.

The voltage waveform of motor-1 supplied by the SC bank through the bidirectional DC/DC converter is shown in Fig. 5; where, the bus voltage of the drive system can be maintained at the required constant bus-voltage in the motor starting state; the power are supplied by the SC, and the voltage of SC bank goes down in this state.

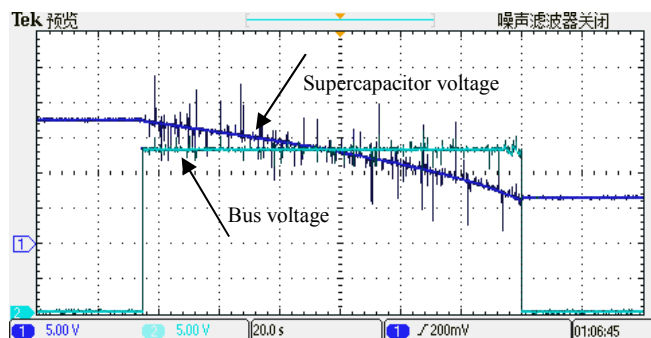

Fig. 5. Waveform of bus voltage and SC voltage in motor starting state

After the motor speed reaches 3200 rpm, disconnect the power bus to put the motor in the electric braking state. The energy generated by the motor electric braking is recovered into the SC bank by means of constant current charging through bidirectional DC/DC converter. This simulates the recovery of electric energy when the vehicle is stopped or downhill.

Fig. 6 shows the operation in the electric braking state of the motor-1, where, the electric braking energy can be quickly saved in the SC bank during the motor electric braking state. The SC voltage rises step by step in this state,

which means that the kinetic energy of the EV is converted into electric energy and saved in the SC bank. It can be seen from the figure that the SC bank voltage rises from the initial 0.4V to 1.55V.

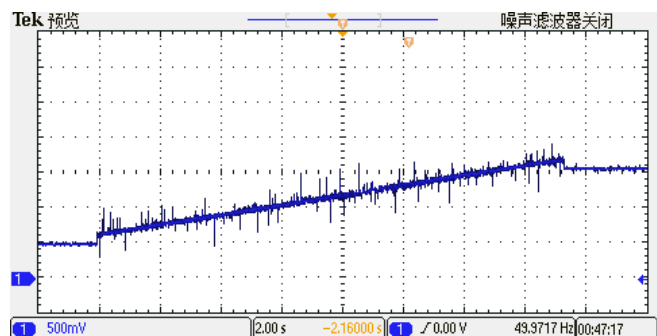

Fig. 6. Waveform of the electric brake energy recovery of the motor-1

The motor-2 is also electric braked from the same speed, and the electric braking energy recovery waveform is shown in Fig. 7. As can be seen from the figure, the SC bank voltage rises from the initial 2.4V to 3.2V.

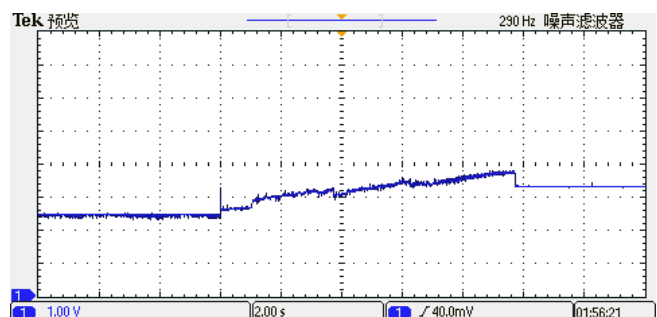

Fig. 7. Waveform of the electric brake energy recovery of the motor-2

IV. ANALYSIS OF MOTOR ELECTRIC BRAKING ENERGY RECOVERY EFFICIENCY AND CONSUMPTION

A. Recovery Efficiency Analysis

The motor electric braking energy recovery process is relatively complicated, involving many factors and links, such as the transmission system, control system, and motor operation. The kinetic energy recovery system includes SC bank, bidirectional DC/DC converter, rectifier and motor. In this paper, the kinetic energy recovery efficiency formula of the motor is as follows:

$$\eta = \frac{W_c}{\Delta W} \times 100\% \quad (5)$$

where, W_c is the energy recovered into the SC bank, ΔW is the change of the kinetic energy of the motor.

The kinetic energy change formula of the motor is:

$$\Delta W = J(\omega_2^2 - \omega_1^2)/2 \quad (6)$$

$$\omega = 2\pi n/60 \quad (7)$$

where, J is the moment of inertia ($kg \cdot m^2$) of the flywheel, ω is the angular velocity (rad/s) of the motor, n is the motor speed (rpm). In this system, the motor speed is decelerated

from 3200 rpm to stop. From (6) and (7), the kinetic energy change (ΔW) of the motor during electric braking is 176.8J.

The formula of the energy change recovered into the SC bank is:

$$W_c = C(U_2^2 - U_1^2)/2 \quad (8)$$

where, C is the total capacity of the SC bank, U_2 is the final voltage of the SC bank after the energy recovery, and U_1 is the initial voltage of the SC bank. In the electric braking energy recovery test of motor-1, the kinetic energy recovery efficiency can thus be known as 18.4% by using (5) and (8). In the electric braking energy recovery test of motor-2, the kinetic energy recovery efficiency can be known as 37.2%.

B. Analysis of Energy Consumption

The electric braking energy generated by the system mainly flows through the motor, rectifier, bidirectional DC/DC converter, and the SC bank. Each link inevitably loses a certain amount of energy, and the flywheel driven by the motor will also be affected by wind resistance. The energy recovered into the energy storage device can only be part of the electric motor braking energy. The energy consumption rate of the system can be expressed by the following formula:

$$\eta_s = \int_0^T (P_e + P_{z1} + P_{dc} + P_c) dt / \Delta W \quad (9)$$

where, P_e is the power loss of the motor, P_{z1} is the power loss of the rectifier, P_{dc} is the power loss of the bidirectional DC/DC converter, P_c is the power loss of the SC bank.

The loss power of the motor is mainly the internal copper loss of the motor, i.e.

$$P_e = I^2 R \quad (10)$$

Therefore, the energy consumption rate of the motor can be expressed by the following formula:

$$\eta_e = \frac{3}{2} \int_0^T P_e dt / \Delta W = \frac{3R}{2} \int_0^T i^2(t) dt / \Delta W \quad (11)$$

where, $i(t)$ is the drive bus current, R is the phase resistance, T is the motor electric braking time. The phase resistance of the motor-1 is 1.3Ω , and the bus current during electric braking is collected by oscilloscope, the internal loss rate of the motor can be calculated is 47% by (11). The phase resistance of the motor-2 is 0.4Ω , the internal loss rate of the motor during electric braking can be calculated as 25% by (11). It can be seen that the loss of the motor accounts for a large part of the electric braking energy during the test. In the same recycling system, the energy recovery efficiency of the motor-2 is significantly better than that of the motor-1. Therefore, for improving the recovery efficiency of electric braking energy, the value of motor consistent k_m must be increased. In this test, the k_m values of the two motors used are relatively small, and the k_m values of many motors used in electric vehicles is

much larger than this value, Some even reach $420 Nm / \sqrt{w}$. Therefore, when an electric vehicle adopts a kinetic energy recovery system, the recovery efficiency should be greatly improved.

V. CONCLUSIONS

This paper introduces the technology and control strategy of electric braking energy recovery system with SC. The experimental results verify the feasibility of the control strategy and the fast energy recovery function of the SC bank in the system. The system described in this paper can recycle the energy of EVs. From the test results, the kinetic energy storage system based on the SC is effective, but the efficiency of the motor's kinetic energy recovery system involves multiple links, especially the value of the motor constant k_m . To improve the energy recovery efficiency of the system, key components such as high-efficiency and high-conversion rate DC/DC converters and motor drivers are also required.

REFERENCES

- [1] K. Bellache, M.B. Camara and B. Dakyo, "Multi-physical characterization of supercapacitor," 2017 Twelfth International Conference on Ecological Vehicles and Renewable Energies (EVER), Monte Carlo, pp. 1-5, 2017.
- [2] Hamid Gualous, Hasna Louahlia, and Roland Gallay, "Supercapacitor Characterization and Thermal Modelling with Reversible and Irreversible Heat Effect", IEEE Transaction on Power Electronics, vol. 26, NO. 26, PP.3402-3409, NOVEMBER 2011.
- [3] S. Harpool, A. von Jouanne and A. Yokochi, "Supercapacitor performance characterization for renewables application," 2014 IEEE Conference on Technologies for Sustainability (SusTech), Portland, OR, pp.160-164, 2014.
- [4] M. Ortuzar, J. Dixon, J. Moreno. "Design construction and performance of a buck-boost converter for an ultracapacitor-based auxiliary energy system for electric vehicles". Industrial Electronics Society, 22 (3):2889-2894, 2003.
- [5] Chandu V. V. Muralee Gopi and H. kim, "Design of Supercapacitor for Electric and Hybrid Vehicles: Supercapacitor," 2018 International Conference on Information and Communication Technology Robotics (ICT-ROBOT), Busan, pp. 1-3, 2018.
- [6] H. Gualous, M.B. Camara, B. Boudrat, R. Gallay and B. Dakyo, "Supercapacitor characterization for electric vehicle applications," 4th International Conference on Power Engineering, Energy and Electrical Drives, Istanbul, pp. 1591-1596, 2013.
- [7] Xiaoli Chen, Daqiang Liang, and Weidong Zhang, "Braking Energy Recovery for Electric Traction Based on Super-capacitor and Bidirectional DC-DC Converter," Proceedings of the 7th International Power Electronics and Motion Control Conference, Vol.2, pp.879-883, 2012.
- [8] A. Taut, O. Pop, and E. Ceuca, "System for Energy Recovering with BLDC Motor at Deceleration Momentum," Proceedings of the 36th International Spring Seminar on Electronics Technology, pp.299-304, 2013.
- [9] Wang Mian, Tian Ye, Li Tiemin, et al, "Study of bidirectional DC-DC converters applied to energy storage system," Transactions of China Electrotechnical Society, 2013, 28(8):66-71.